

HAZARD INTENSITY LEVELS

1. **DANGER:** Failure to comply will result in severe personal injury or death and/or property damage.
2. **WARNING:** Failure to comply could result in severe personal injury or death and/or property damage.
3. **CAUTION:** Failure to comply could result in minor personal injury and/or property damage.

**OPTIONS CW1, CW2, CW3
BLOWER/FILTER CABINET**

INSTALLATION FORM RZ-NAI-B-BF
Obsoletes Form RGM 434/436-BF-A



APPLIES TO:

Model B

Option Description

The blower/filter cabinet option is designed for field assembly and must be installed on the heater prior to heater installation. Option CW1 includes filter racks that are adaptable for 1" or 2" filters but does not include the filters. Option CW2 includes 1" permanent aluminium filters. Option CW3 includes 2" permanent filters.

Application NOTE: Cabinet also fits no longer manufactured Reznor Model BE.

Check the parts in the option package with the following list. **SAVE THE CARDBOARD PACKING INSERTS;** they will be used for supports during installation.

The option package includes:	25-50		75		100		125		130		165		200		250-300		400	
	Qty	P/N	Qty	P/N	Qty	P/N	Qty	P/N	Qty	P/N	Qty	P/N	Qty	P/N	Qty	P/N	Qty	P/N
Option CW1- Pkg P/N		101543		101544		101545		140836		101546		101547		101548		101549		101550
Option CW2- Pkg P/N		101628		101629		101630		140884		101631		101632		101633		101634		101635
Option CW3- Pkg P/N		101636		101637		101638		140885		101639		101640		101641		101642		101643
Top and Bottom Panels	2	99707	2	99707	2	99707	2	140841	2	100642	2	100642	2	100642		--		--
Top Right & Btm Left		--		--		--		--		--		--		--	2	101582	2	101584
Top Left and Btm Right		--		--		--		--		--		--		--	2	101583	2	101585
Stiffening Channel		--		--		--		--		--		--		--	2	101551	2	101551
Stiffening Angle		--		--		--		--		--		--		--	2	101601	2	101601
Right Side Hanger Bar	1	101578	1	101578	1	101578	1	101578	1	101580	1	101580	1	101580	1	101580	1	101580
Left Side Hanger Bar	1	101579	1	101579	1	101579	1	101579	1	101581	1	101581	1	101581	1	101581	1	101581
Front Legs	2	99761	2	99762	2	99763	2	137404	2	100634	2	100635	2	100636	2	100637	2	100638
Top Filler Panel Assy	1	101562	1	101563	1	101564	1	140838	1	101565	1	101566	1	101567	1	101568	1	101569
Btm Filler Panel Assy	1	101570	1	101571	1	101572	1	140840	1	101573	1	101574	1	101575	1	101576	1	101577
Rear Legs	2	99708	2	99708	2	99708	2	99708	2	100639	2	100639	2	100639	2	100640	2	100641
Door Panels	2	99712	2	99712	2	99712	2	99712	2	100646	2	100646	2	100646	2	100646	2	100646
Door Stops	2	99711	2	99711	2	99711	2	99711	2	100645	2	100645	2	100645	2	100645	2	100645
Center Fltr Brkt Assy		--		--		--		--	1	101624	1	101624	1	101624	1	101625	1	101626
Filter Angle	2	99710	2	99710	2	99710	2	99710	4	101591	4	101591	4	101591	4	101592	4	101593
Filter Bracket	2	99709	2	99709	2	99709	2	99709	2	101595	2	101595	2	101595	2	101596	2	101597
Parts Bag (see below)	1	101600	1	101600	1	101600	1	101600	1	101600	1	101600	1	101600	1	101600	1	101600
Permanent Aluminum Filters in Option Package CW2 only																		
16" x 20" x 1"		--		--		--		--		--		--		--	2	101607		--
20" x 20" x 1"	1	101608	1	101608	1	101608	1	101608		--		--		--	2	101608		--
16" x 25" x 1"		--		--		--		--	1	101609	1	101609	1	101609		--	2	101609
20" x 25" x 1"		--		--		--		--	1	101610	1	101610	1	101610		--	2	101610
Permanent Aluminum Filters in Option Package CW3 only																		
16" x 20" x 2"		--		--		--		--		--		--		--	2	101620		--
20" x 20" x 2"	1	101621	1	101621	1	101621	1	101621		--		--		--	2	101621		--
16" x 25" x 2"		--		--		--		--	1	101622	1	101622	1	101622		--	2	101622
20" x 25" x 2"		--		--		--		--	1	101623	1	101623	1	101623		--	2	101623

Parts Bag (P/N 101600) includes:

Qty	P/N	Description
118	11813	#10 x 1/2" lg Sheet Metal Screws
14	16246	#1/4 - 20 x 3/4" lg Hex Head Cap Screws
6	7328	#1/4 - 20 Hex Nuts (Keps)
1	101599	Foam Rubber Gasket (1/8"x3/4"x20"lg)
4	82177	Plastic Plug, Niagara Plastics #412-2

Duct Opening Dimensions

Dimensions of Cabinet Opening for Return Air Duct		
Heater Size	Duct Opening (inches)	
	Width	Height
25-125	14-3/4	15-7/8
130-200	20-1/2	23-7/8
250-300	26	23-7/8
400	34-1/4	23-7/8

WARNING: Improper installation, adjustment, alteration, service, or maintenance can cause property damage, injury or death. Read the installation, operation, and maintenance instructions thoroughly before installing or servicing this equipment.

INSTALLATION INSTRUCTIONS

Installation should be done by a qualified agency in accordance with the instructions on this sheet and in compliance with all codes and requirements of authorities having jurisdiction.

Tools Required: Ratchet or preferably cordless screwdriver with 5/16" socket and 3/8" socket (or 3/8" wrench); 7/16" wrench

1. Preparation

All holes are punched at the factory. Use #1/4-20 x 3/4" long machine screws where specified in the instructions. Otherwise, use the #10 x 1/2" long sheetmetal screws.

Except for the crate bottom, remove the shipping crate from the heater. Leave the heater attached to the crate bottom.

2. Install Top & Bottom Filler Panels on Heater

(Filler panels are the two unpainted pieces that "fill-in" the space between the heater and the blower cabinet.)

Install Top Filler Panel (See FIGURES 1 and 2) - Remove the screws from the top back of the heater and re-insert them attaching the top filler panel (use slotted holes). Position top filler panel with the rear flange going down.

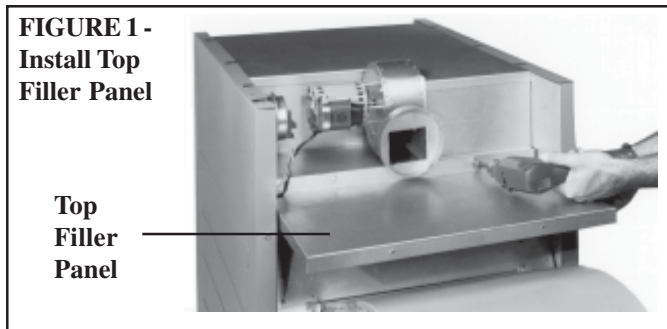

Install Bottom Filler Panel (See FIGURE 2) - Locate the holes in the bottom of the blower adapter back. Using these holes, install the bottom filler panel with the rear flange up.

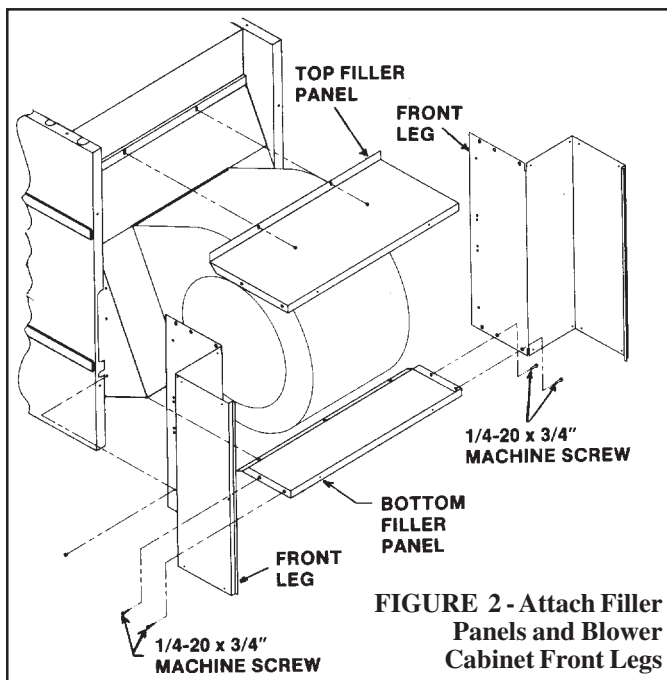

FIGURE 2 - Attach Filler Panels and Blower Cabinet Front Legs

3. Install Cabinet Front Legs on Heater (See FIGURE 2)

Slide the edge of one of the legs (legs are interchangeable) in next to the inner side panel of the heater. Fasten the leg to the heater back panel using the 1/2" long sheetmetal screws. Using the 3/4" long machine screws, attach the leg to the bottom filler panel. Attach the other front leg.

4. Gasket Strips (See FIGURE 3)

Cut the self-adhesive gasket strip into two 10-inch pieces. Attach one of the strips to each side of the top of the blower housing (parallel with the sides).

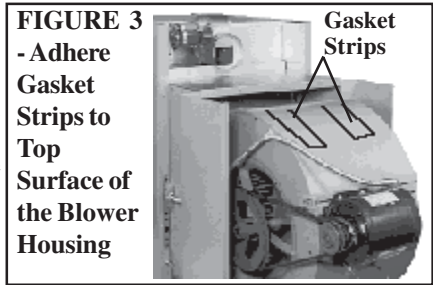
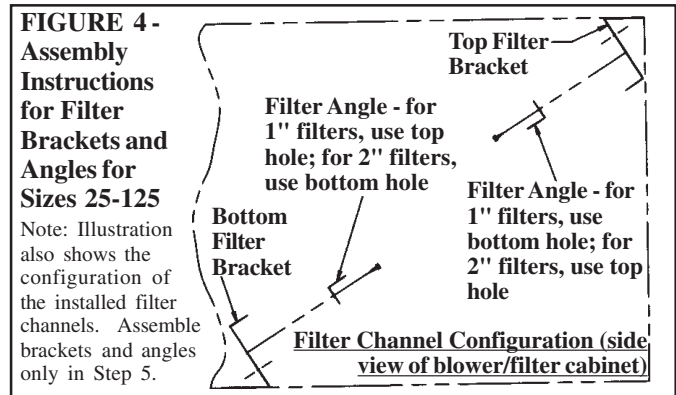

FIGURE 3 - Adhere Gasket Strips to Top Surface of the Blower Housing

5. Assemble Filter Channels

The filter channels are created by assembling the filter brackets and the "L" shaped filter angles. The filter brackets are designed to be used with either 1" or 2" filters. If using 1" filters, attach the filter angles to create a 1" channel on the filter brackets. If using 2" filters, attach the filter angles to create a 2" filter channel. Follow the instructions in the illustrations.

Sizes 25-125 (See FIGURE 4) - Attach one angle to the top filter bracket and one angle to the bottom filter bracket.



Sizes 130-400 (See FIGURE 5) - Package includes four angles. Attach one angle to the top filter bracket and one angle to the bottom filter bracket.

If using 1" filters, attach the two angles to the center filter bracket. If using 2" filters, these two filter angles are not used.

(Note in FIGURE 4 also applies to Sizes 130-400.)

FIGURE 5 - Assembly Instructions for Filter Brackets and Angles for Sizes 130-400

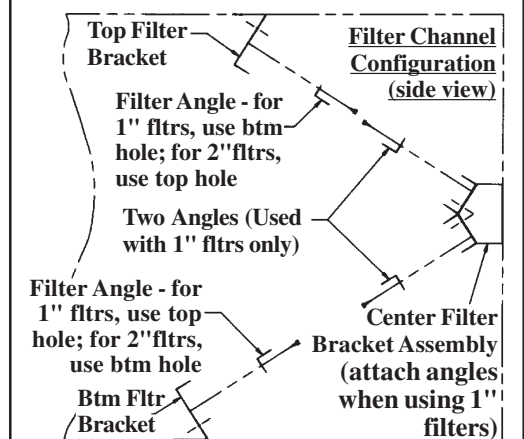

INSTALLATION NOTE: For reasons of clarity, the illustrations in **FIGURES 6-11** show only the filter brackets (not the assembled channels).

6. Assemble the Cabinet Bottom (See FIGURE 6)

Sizes 25-200 - On the **inside** of the cabinet bottom, attach the door stops and the bottom filter bracket. See (a) and (b) below. Insert the screws so that the ends will be inside the cabinet.

(a) Attach the door stops along the side edges.

(b) Attach the assembled filter channel across the cabinet bottom using the row of holes that will be closest to the heater. **The filter channel on the bottom should face away from the heater.**

Sizes 250-400 - Position the two bottom cabinet pieces with the outer sides up. Position the stiffening channel over the seam. Attach the two cabinet bottom pieces and the stiffening channel. Screw ends should be inside the channel.

On the **inside** of the cabinet bottom, attach the stiffening angle, the door stops, and the bottom filter channel. See (a), (b) and (c) below. Insert the screws so that the ends will be inside the cabinet.

(a) Attach the stiffening angle to the edge of the rear opening.

(b) Attach the door stops to the side edges.

(c) Attach the assembled bottom filter channel across the cabinet bottom, using the row of holes in the cabinet bottom that will be closest to the heater. **The filter channel should face away from the heater.**

7. Assemble the Cabinet Top (See FIGURE 7)

Sizes 25-200 - Attach the assembled top filter channel across the **inside** of the cabinet top using the holes that are closest to the rear opening of the blower cabinet.

Sizes 25-125 - The top filter channel should face the heater. **Sizes 130-200** - The top filter channel should face away from the heater. Screw ends should be inside the cabinet.

Sizes 250-400 - Position the two top cabinet pieces with the outer sides up. Position the stiffening channel over the seam. Attach the two pieces and the stiffening channel. Screw ends should be inside the channel.

On the **inside** of the cabinet top, attach the stiffening angle and the top filter channel. See (a) and (b) below. Screw ends should be inside the cabinet.

(a) Attach the stiffening angle across the rear opening.

(b) Attach the assembled top filter channel across the cabinet top, using the row of holes in the cabinet top that is closest to the rear of the cabinet. **The filter channel should face away from the heater.**

FIGURE 6 - Assemble Cabinet Bottom

- **Sizes 25-200** -- Cabinet bottom is one piece; attach the door stops and the bottom filter channel assembled in Step 5 (with the filter channel facing away from the heater)
- **Sizes 250-400** -- Cabinet bottom is two-piece; use the stiffening channel to assemble the two sections and attach the rear support angle, the door stops, and the bottom filter channel assembled in Step 5 (with the filter channel facing away from the heater)

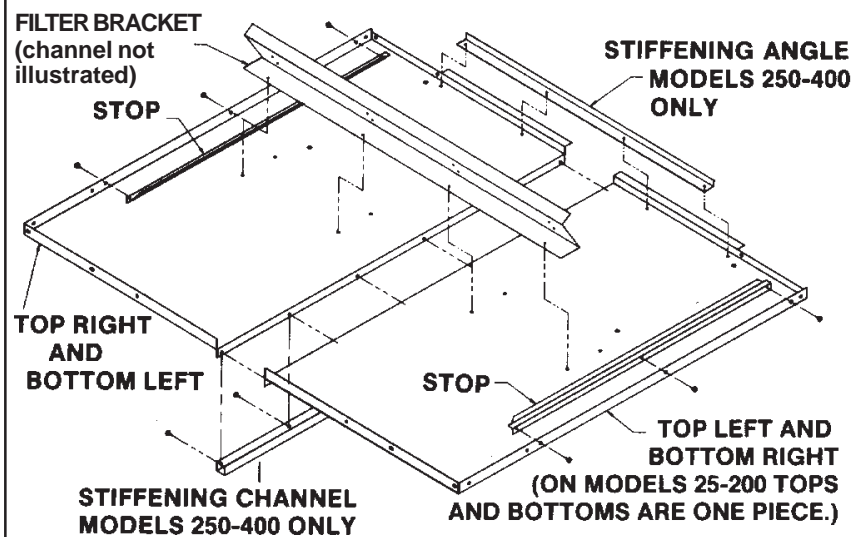
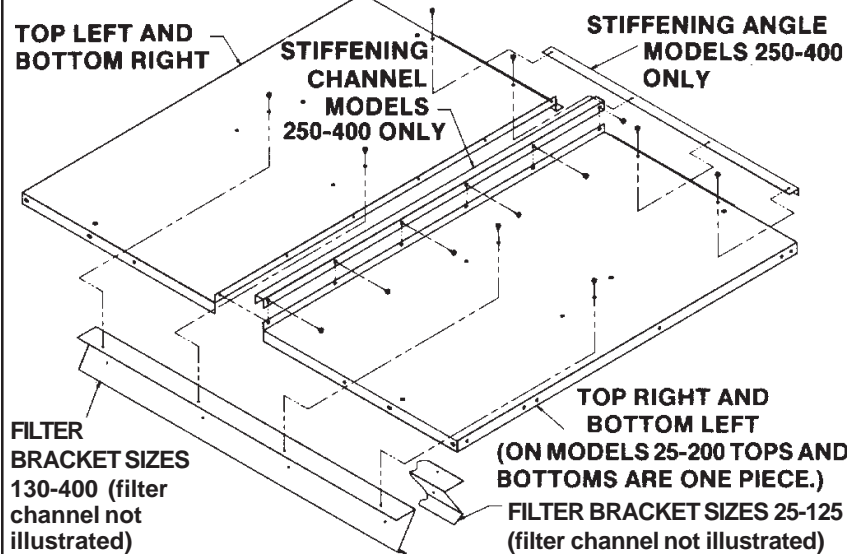

FIGURE 7 - Assemble Cabinet Top

- **Sizes 25-125** -- Top is one piece; attach the top filter channel assembled in Step 5 (with the filter channel facing the heater)
- **Sizes 130-200** -- Top is one piece; attach the top filter bracket assembled in Step 5 (with the filter channel facing away from the heater)
- **Sizes 250-400** -- Top is two-piece; use the stiffening channel to assemble the two sections and attach the rear support angle and the top filter channel assembled in Step 5 (with the filter channel facing away from the heater)



8. Attach Assembled Cabinet Bottom to Heater (See FIGURE 9 on page 4.)

- 1) Remove the blower shipping supports and discard.
- 2) Fold the two cardboard packing inserts (See **FIGURE 8**) along the scored lines. Place the cardboard support tubes on the corners of the crate bottom rear cross brace.
- 3) Slide the cabinet bottom under the blower, with the rear corners setting on the cardboard supports. Lift the front corners of the bottom panel and position them over the front legs of the blower cabinet.
- 4) Attach the cabinet bottom panel to the front legs and to the bottom filler panel.

FIGURE 8 - Use Cardboard Packing Inserts as Corner Supports

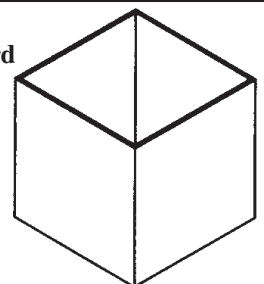

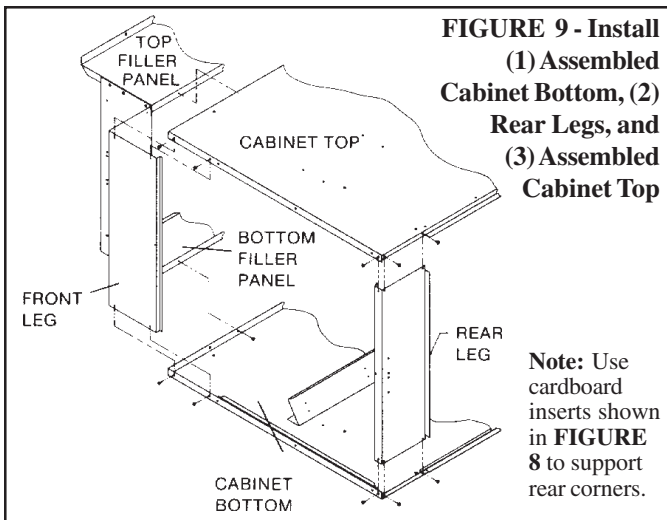

9. Attach Rear Cabinet Legs (See FIGURE 9)

Rear legs are interchangeable. Attach one leg to each corner of the bottom panel.

10. Install Cabinet Top (See FIGURE 9)

Set the cabinet top assembly over the rear legs and lower it onto the front legs. Attach the top to the front legs, the top filler panel, and the rear legs.

11. Install Hanger Bars (See FIGURE 10)

Position the hanger bar on the outside of the cabinet top with the open side of the channel toward the edge of the cabinet. The end of the hanger bar should be even with the rear of the cabinet top. Fasten the hanger bar to the cabinet top by inserting the 3/4" machine screws up through the cabinet top and into the channel on the hanger bar. Fasten with nuts.

Attach the hanger bar to the front legs and the filler panel with 3/4" machine screws.

Install the second hanger bar on the other side of the cabinet top.

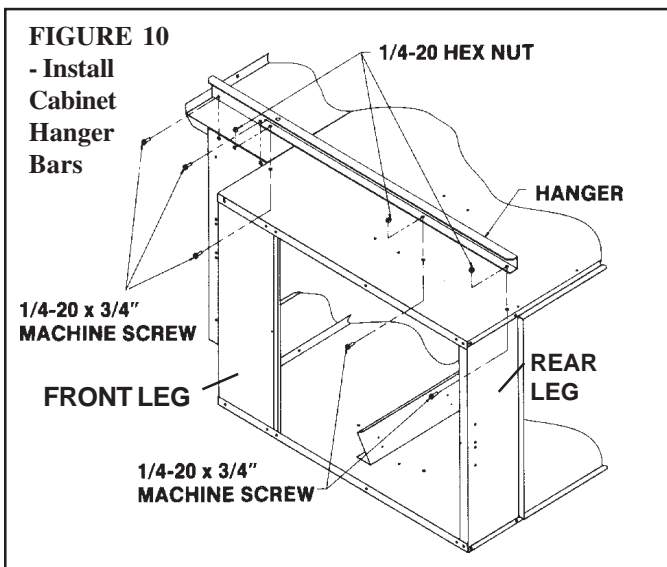

12. Install Filter Bracket -- Sizes 130 - 400 (See FIGURE 11)

Sizes 130-400 require center filter channels. There are four holes in the rear legs. Using the top and third hole, attach the center filter bracket assembly across the inside of the rear opening of the filter cabinet.

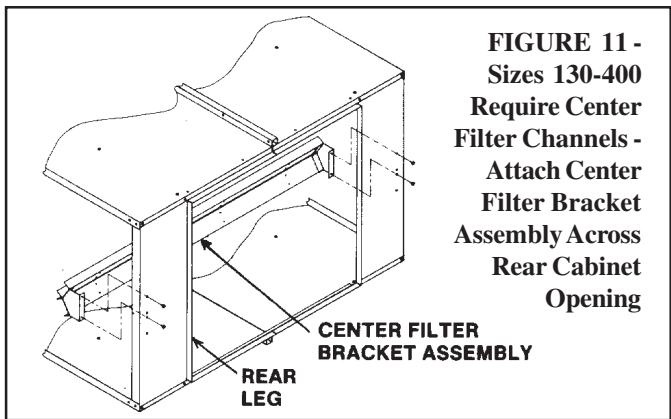

Slide the filters into the channels on the filter brackets. The arrows on the filters should be the same direction as the airflow.

If installing the Option Package CW1 (without filters), you will need to supply either 1" or 2" metal filters in the sizes listed in the table.

Filter Size	Model Size	Filter Quantity	Filter Size
	25-125	1	20 X 20
130-200	1	16 X 25	
	1	20 X 25	
250-300	2	16 X 20	
	2	20 X 20	
400	2	16 X 25	
	2	20 X 25	

13. Installing the Doors

Install the doors by lifting them up into the side of the blower cabinet and lowering them into the channels made by the door stops. Attach the doors with 1/2" long screws. Snap the plastic plugs into the holes in the doors.

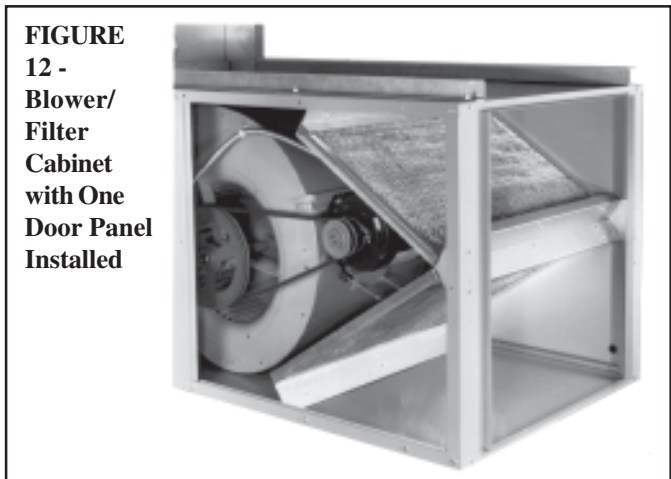

14. Heater Installation

Construction of the blower/filter cabinet is now complete. Leave the crate bottom and cardboard supports in place until the heater is suspended.

Each hanger bar has a suspension hole located at the correct balance point. This heater with a blower/filter cabinet requires four-point suspension using the balance points on the hanger bars and the heater hanger brackets closest to the front of the heater. The hanger bar is designed to be used with field-provided 3/8" threaded rods and nuts (the same as the hanger bracket assembly on the heater).

Install the heater according to the instructions in the installation manual. The blower cabinet opening may be connected to a return air duct. See the dimensions on the bottom of page 1.

REZNOR®

(800) 695-1901; www.RezSpec.com

©2014 Reznor, LLC. All rights reserved.
 MANUFACTURER OF GAS, OIL, ELECTRIC HEATING AND VENTILATING SYSTEMS
 Trademark Note: Reznor® is registered in the United States and other countries.
 0514 POD OG Form I-B-BF (Version 0.1)

Printed in U.S.A.